

Genus creates innovative products for the video and photography professional. Discover our full range of Matte Boxes, Shoulder Mounts, Sunshades, Viewfinders and Filters.

Sunshade

- Clips onto your lens and fastens with ease
- Fits a large range of lenses, both standard and wide
- Has a lockable filter holder that will rotate 360 degrees
- Selection of screw in adapter rings to fit lenses up to 82mm diameter
- Wide Rayshade to accommodate wide-angle lenses



Adapter GSS

Genus Matte Box

- Clips onto your lens and fastens with ease
- Wide rayshade to accommodate wide-angle lenses
- Fits a large range of lenses, both standard and wide
- Two filter trays; one wide and one standard 360° rotatable
- Clamp ring caters to lenses and wide angle adapters up to 105mm
- A Do-Nut adapter ring ensures a snug fit between the lens adapter ring and the clamp ring of the matte box
- A selection of screw-in adapters rings to fit 37mm – 82mm lenses are available



Adapter GWMC

Matte Box Basic Kit

- French Flag added to Wide Angle Matte Box
- Gives better level of light control
- Specify lens size for adapter ring



Adapter GMKBAS

Matte Box DSLR Kit

- Adapter Bar System for DSLR (GMB/DSLR) added to Basic Matte Box Kit
- Designed with the DSLR camera in mind
- You can maneuver your mounted camera horizontally and vertically for perfect alignment
- The high base plate can accommodate additional accessories to your camera
- Retracts to a compact size when not in use



Adapter GMKDSLR

Matte Box Superior Kit for Video Cameras

- Adapter Bar System (GMB/A) for video cameras added to the Matte Box Basic Kit
- You can move your mounted camera horizontally and vertically for perfect alignment
- Back plate and bars can be extended for any camcorder/lens size
- Retracts to compact size when not in use
- Specify lens size for adapter ring



Adapter GMKSUP



Adapter Bars System for DSLR Cameras

- High base plate to accommodate the addition of external accessories to your camera
- Variable positioning with vertical & horizontal brace for perfect alignment
- Retracts to a compact size when not in use
- Easy-grip turn knobs that tighten and loosen gently
- Bars can be elongated by attaching extra bars into the specially designed threaded cores



Advanced Adapter Bar System

- Backplate & Bars can be extended for longer camcorder / lens reach
- Backplate slides out completely for easy attachment to your camera / camcorder
- Variable positioning with vertical & horizontal brace for perfect alignment
- Retracts to a compact size when not in use
- Non-slip rubber strips on the backplate prevents movement & damage to your camcorder

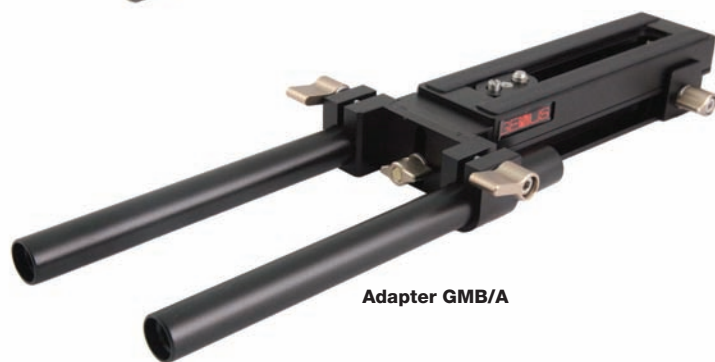

Adapter Plate

- The GAP adapter plate clips onto Sony V mount tripod
- This camera base plate adapter allows small camcorders to be easily attached to Sony VCT-14 camera base plates
- Great for use on remote camera heads



GMB/P Genus Professional Bar System.

- Professional Adapter Bars System (GMB/P) is specifically designed to cater to the ENG camera market.
- Clicking snugly and securely onto a Sony V-mount plate or its equivalent, the GMB/P serves the dual function of a bar system as well as a camera adaptor plate.
- The GMB/P comes supplied with 215mm support bars which can be removed when not in use, leaving the plate attached to the underside of the camera.



Superior Follow Focus

- Ultra-smooth action when adjusting focus
- Snap-On Bar quick release system, 15mm (3/5") diameter bars by 60mm (2 2/5") spacing
- Sliding Bracket, moving the Follow Focus Gear Box Assembly away from the lens, enables you to change lens without de-rigging
- Flippable Gear-Box action for Nikor lenses
- Reversible Pitch Gear action for short length lenses
- Backlash elimination system within the Gear-Box
- High specification aluminum & acetal construction
- Stainless steel fixings
- Full range of Pitch Gears
- Flexible Belt Gear option available
- Standard 12mm (1/2") whip drive aperture
- 360 degree adjustable
- Positive Drag Pressure
- Beveled / 3D marking disc means the operator can shoot and see the focus mark. Especially handy for the DSLR camera videographer

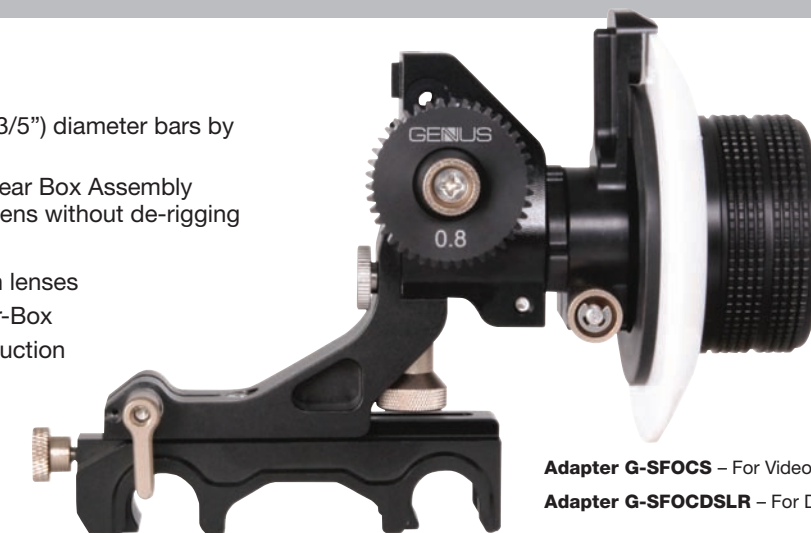

Bravo Follow Focus

- Ultra-smooth action when adjusting focus
- Sliding Bracket, moving the Follow Focus Gear Box Assembly away from the lens, enables you to change lens without de-rigging
- Reversible Pitch Gear action for short length lenses
- Backlash elimination system within the Gear Box
- High specification aluminum & acetal construction
- Stainless steel fixings
- Flexible Belt Gear option available
- Standard 12mm (1/2") whip drive aperture
- 360 degree adjustable
- Positive Drag Pressure
- Beveled / 3D marking disc means the operator can shoot and see the focus mark. Especially handy for the DSLR camera videographer



Shoulder Mount System

- Versatile and Modular System enables you to build the rig to suit you and your camera
- Comes as a "Kit" or in individual components so you can have exactly what you need
- Quick and easy to assemble / disassemble
- Camera Mount Bracket has adjustable vertical bracket for DSLR cameras
- The counterweight is not in the shoulder weight, therefore giving your shoulder the true pivot point and making balance easier



Adapter GARD-NK

Nuns Knickers

- Snug Fit for Donut Ring
- Tough Fabric Sleeve
- Flexible Material for Easy Handling
- Elasticated for Use with Different Lenses
- Prevents Light Leaks
- Easy to Install
- Lightweight and Compact



Adapter GVISTA

Porro Viewfinder

- Lightweight construction
- Easy attachment LCD mount frame
- Two viewfinders: one for landscape (horizontal) shooting and one for portrait (vertical) shooting
- Viewfinders attach to the mount frame by velcro, making it easy to change between viewfinders
- Changes from low level to above-head shooting just by turning the viewfinder around 180°
- Can easily be converted into a sunshade simply by lifting and sliding the moveable flap
- Set comes with two velcro LCD mount frames
- Packs away into handy protective boxes



GNDF

GNDF Genus Neutral Density Fader

- The Genus ND Fader is a compact all-in-one variable neutral density fader filter that has up to 4 stops of light reduction.
- Giving you clear and precise shots at whichever density you are using the GNDF screws beautifully onto your lens and is an invaluable tool to enhance your images.
- Available in diameters of 52mm, 58mm, 62mm, 67mm, 72mm, 77mm & 82mm
- The front diameter glass element is wider to reduce the risk of clipping and vignetting.
- Each ND fader comes with a handle, and dust cloth & it's own case.

Adapter GLV



Loupe Viewfinder

- The Genus Loupe Viewfinder is the ultimate tool for use with 3-inch LCD screens
- With a 2.5X magnifying lens you clearly see your images on a larger scale
- Easy to install and adjust
- The Genus Loupe Viewfinder Kit comes with one black hood, one translucent hood, a mounting frame, magnifying lens and a lanyard



Adapter GSBK

Shoulder Brace Kit

- Versatile and Modular System enables you to build the rig to suit you and your camera
- Comes as a 'Kit' or in individual components so you can configure for your shooting style
- Easy and quick to assemble / disassemble
- Camera Mount Bracket has adjustable vertical bracket for DSLR and mini camcorder cameras.
- Brace gives your shoulder the true pivot point making balance easier
- Adds stability to your shots by creating extra body contact



Adapter GKPCR

Ki Pro Cage

- Retractable Handle for easy carrying
- Made from aviation grade aluminum
- Protects Ki Pro from bumps and damage
- Modular and flexible design
- Option to attach external battery
- Lightweight and sturdy
- Tripod mountable
- Adjustable center of gravity
- Height adjustable
- Supports industry standard 15mm rods



Height Extension Bracket for GWMC matte box

When working with variable diameters of camera and lens configurations this Height Extension Bracket enables you to position the matte box centrally and with ease.

Adapter G-HEB



Adapter G-ARRB

Adjustable Rod Riser Bracket

This takes away the problem of getting, for example, a follow focus in the right position or adding accessories via a bar clamp / swing arm such as a monitor.



Adapter G-FRRB

Fixed Rod Riser Bracket

For those who have a GWMC and want to use the Matte Box with a Shoulder Mount Kit, but not as a clip on, or want to use Nuns Knickers this bracket allows you to work in this fashion.

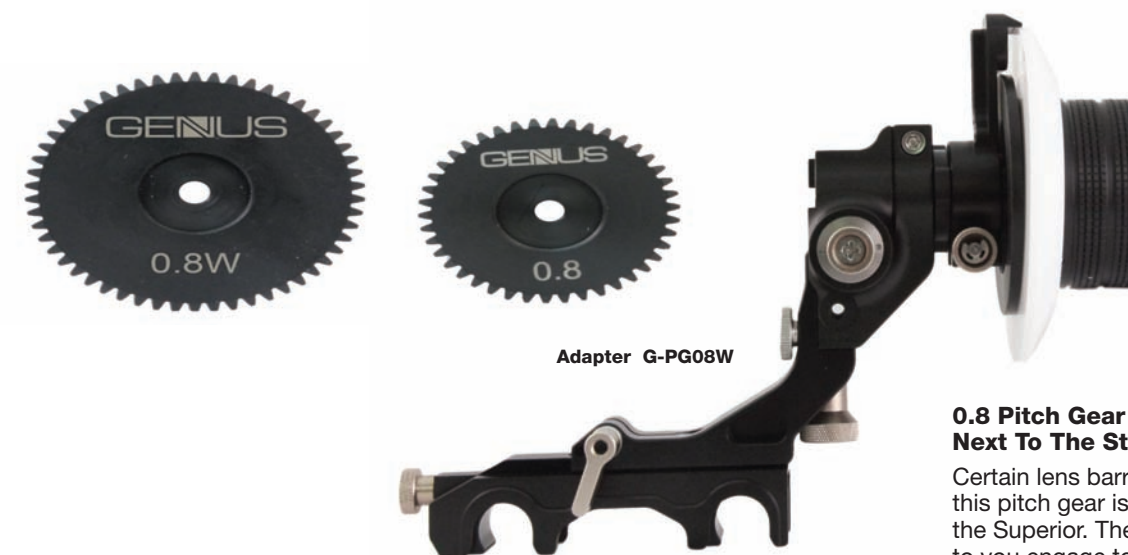

Adapter G-PG08W

0.8 Pitch Gear Wider Version – Next To The Standard Version

Certain lens barrels are so wide that this pitch gear is needed when using the Superior. The extra diameter allows you to engage to the flexible lens gear without touching the lens housing.



Adapter GMB-HP

Hot Plate Professional Adapter Bars System

Designed specifically for the new Video Cameras being launched at NAB. Cameras such as the Sony F3 and Panasonic AF100. Comes c/w 215mm & 200mm Extension rods to comfortably support the camera bodies with their lenses. There are 4 fixing points to the bars for ultra stability.



LG GVSMK

Genus Video Shoulder Mount Kit

A specifically designed product for the new video cameras. Come c/w the hot plate and the heavy duty pad. A modular system to be configured to suit your needs.



Adapter GCSM-HDPAD

Fixed Rod Riser Bracket

If working with a heavier load, or for long periods of time this Heavy Duty pad takes the weight off your shoulders, and makes operating your camera more comfortable.

